



sasol 
SOLAR
CHALLENGE

INNOVATION BEYOND BOUNDARIES



TECHNICAL REGULATIONS



Table of Contents

2022 Sasol Solar Challenge Technical Regulations.....	2
Introduction and Welcome	2
The major changes for 2022 include:	2
Special Credits	3
1. Solar Car Regulations.....	3
1.1. Classes.....	3
1.2. Dimensions	3
1.3. Wheels.....	4
1.4. Solar Collector.....	4
1.5. Energy Storage	4
1.6. Vehicle Identification.....	7
1.7. Signage	7
1.8. Ballast.....	8
1.9. Tracker.....	9
1.10. Safety	9
1.11. Occupant Cell	10
1.12. Seats.....	11
1.13. Occupant Space	11
1.14. Safety-belts	12
1.15. Egress.....	12
1.16. Cooling and Hydration.....	13
1.17. Forward and Sideward Vision	13
1.18. Rear Vision	14
1.19. Steering.....	14
1.20. Stability.....	15
1.21. Brakes.....	16
1.22. Tyres.....	17
1.23. Driving and Reversing	17
1.24. Lighting	17
1.25. Audible Warning Device	20
1.26. Instrumentation	20
1.27. Automatic Functions.....	20
1.28. Electrical Safety	20
1.29. Electrical Safe State.....	22
Glossary	24



2022 Sasol Solar Challenge Technical Regulations

Introduction and Welcome

Benjamin Franklin famously stated, “Out of adversity comes opportunity”. The Sasol Solar Challenge has for more than 12 years represented a unique opportunity for young minds to come together and challenge themselves and the establishment, around what is possible. The event represents the very best of what we as human beings can achieve. Our primal need to shape the world around us is more prominent than ever, but instead of shaping it, we are learning to work alongside it, and for it.

As the world starts to recover from its single biggest adversity in recent memory we have been reminded, sometimes very starkly how fragile our home is. It is against this backdrop that teams will once again gather in what is widely regarded as the birth of modern man, Africa! A place of deep tradition and history, one where the sun occupies a place as an almost mythical being, bringer of life and magic.

The African Sun is calling all who seek to harness her power and energy, challenging them to defy the most ancient of continents. At the tip of this great land lies a challenge, an investment in the future of mankind, an opportunity to make new.

This is the Sasol Solar Challenge, this is Africa.

Welcome!

Robert Walker
Sasol Solar Challenge Event Director

The major changes for 2022 include:

- Challenger Class solar cars must have three or more wheels.
- New ground clearance requirements based on automotive standards.
- New turning circle requirements.
- Solar collectors must have low environmental toxicity.
- A standard manikin must fit into each seat.
- Teams must have the dynamic stability of their solar car certified.
- The emergency safe state may not have any voltage or current present outside of energy storage packs or the solar collector.
- Solar cars must have daytime running lamps.
- The registration plate must be mounted at the rear of the solar car.



- Teams must have their solar cars re-certified after making significant repairs.

The information contained in this document is for the purposes of conducting the 2022 Sasol Solar Challenge and must not be regarded as constituting definitive instructions as to how a solar car should be constructed or operated.

Additional information or clarification of the intent of regulations is included in italics.

Please pay meticulous attention to all elements of this document to ensure your team's compliance with these regulations.

Special Credits

Technical Regulations ©Bridgestone World Solar Challenge, used with permission.

1. Solar Car Regulations

1.1. Classes

1.1.1. The 2022 Sasol Solar Challenge will have three classes of solar car:

- Challenger Class is for single-seater solar cars designed to be efficient
- Cruiser Class is for efficient, practical solar cars with two or more seats
- Adventure Class is for solar cars designed to participate in previous events but not eligible for Challenger or Cruiser Class. Adventure Class is non-competitive

1.2. Dimensions

1.2.1. When driving in a straight line, the solar car must fit inside a right rectangular prism 5,000 mm long, 2,200 mm wide and 1,600 mm high, with the base of the prism coincident with the ground.

1.2.2. The eyes of every occupant must be more than 700 mm above the ground.

1.2.3. When driving on a flat road, all parts of the fully laden solar car except the tyres, wheels and wheel hubs must be at least 100 mm above the ground.

1.2.4. The fully laden solar car must be able to drive over a road apex formed by a 1:15 incline followed by a 1:15 decline without any part of the solar car other than the tyres touching the road.



The length of the road apex will be greater than the wheelbase of the solar car.

1.2.5. The fully laden solar car must have an approach angle of at least 10° and a departure angle of at least 10°.



1.3. Wheels

1.3.1. Challenger Class solar cars must be supported by at least three wheels while driving. Cruiser Class solar cars must be supported by at least four wheels while driving.

1.3.2. The fully laden solar car should not tip when tilted by 45° about each pair of adjacent tyre contact patches.

The team's certifying engineer must approve the stability and the rollover propensity of the solar car.

1.4. Solar Collector

1.4.1. A standard solar collector uses silicon photovoltaic cells without reflectors or concentrators. Teams wanting to use reflectors, concentrators or some other form of solar collector must send details of the proposed solar collector to the event organisers for approval.

The power generated by a proposed non-standard solar collector should be no more than the power generated by a standard solar collector. The materials should have low environmental toxicity; this precludes the use of GaAs, CdTe and CuInSe₂. Teams wishing to use non-silicon materials of low environmental toxicity, such as perovskites or organic solar cells, should contact the event organisers. Where the solar collector employs reflectors or concentrators, the allowable aperture of the solar collector should not exceed that of a standard solar collector.

1.4.2. For standard solar collectors, the total cell area must not exceed 4,000 m² for Challenger Class teams and 5,000 m² for Cruiser Class teams.

1.4.3. Cell area calculations must be based on flat, unconnected cells. For cells used without overlapping, the cell area is defined as the projected area of the cell in a direction perpendicular to the plane of the cell. For cells that are overlapped, the cell area is defined as the exposed surface area of the cell. The cell area includes active material, busbars, fingers, and connection pads.

Example calculation: The area of a SunPower cell with a width of 125 mm and a diagonal diameter of 166 mm is less than 0.0155063 m², and so the area of 257 cells is less than 3.9852 m² and the area of 322 cells is less than 4.9931 m².

1.4.4. All devices used for solar charging must be carried in the solar car. This includes stands, supports, and cables.

1.5. Energy Storage

1.5.1. A solar car may store energy. A standard energy storage system uses rechargeable electrochemical cells. Teams wanting to use some other form of energy storage must send details of the proposed energy storage system to the event organisers for approval.

1.5.2. If the energy storage system comprises rechargeable electrochemical cells all with the same chemistry, then the allowable total cell mass for Challenger Class and Adventure Class solar cars is:



Electrochemical cell chemistry	Allowable total cell mass (kg)
Li-S	15.00
Li-ion	20.00
Li-polymer	20.00
LiFePo ₄	40.00

The allowable total cell mass of rechargeable electrochemical cells is not restricted for Cruiser or Adventure Class solar cars. However, the external energy used by a Cruiser Class solar car, including the energy stored at the official start of the challenge, will influence the team's score.

- 1.5.3. Teams wanting to use other cell chemistries, or a mix of cell chemistries must send details of their proposed energy storage system to the event organisers for approval. The Chief Energy Scientist will determine the allowable configurations.
- 1.5.4. The table below shows the maximum number of cells allowed for Challenger Class solar cars using Li-ion cells with size designator '18650', '20700' or '21700'. For all other cell sizes and types, the cell mass will be deemed to be the maximum cell mass specified in the detailed cell model specification provided by the manufacturer.

Cell size	Number of cells (Challenger Class)
18650	420
20700	315
21700	285

If the manufacturer specifies a nominal cell mass and a tolerance, the maximum cell mass is the nominal cell mass plus the positive tolerance.

- 1.5.5. Specification from third party suppliers or found on the internet might not match those endorsed by manufacturers. If the event organisers receive a conflicting or unclear specification of cell mass for a cell model, the Chief Energy Scientist will determine the nominal cell mass for cells of that model.
- 1.5.6. The sum of deemed cell masses (i.e., summed over all cells) must be not more than the allowable total cell mass.
- 1.5.7. The energy storage system must be contained within at most two packs.
- 1.5.8. Electrochemical cells must not, at any time, be operated outside of the operating ranges for voltage, current, and temperature specified by the manufacturer. Teams must provide the manufacturer's specification that includes:
- Minimum operating cell voltage
 - Maximum operating cell voltage



- Maximum discharge current
 - Maximum charge current
 - Maximum temperature while discharging
 - Minimum temperature while charging
 - Maximum temperature while charging
- 1.5.9. The solar car must automatically prevent electrochemical cells from being operated outside the operating ranges for voltage, current, and temperature specified by the manufacturer. Teams must provide an endorsement by their certifying engineer that an adequate and effective automatic battery management system has been designed and implemented so that fault conditions will be managed safely.
- 1.5.10. Batteries used only to
- Power a real-time clock when the solar car is turned off; or
 - Retain data when the solar car is turned off; or
 - Power wireless tyre pressure monitors
- are not considered to be part of the energy storage system, provided that the total energy capacity does not exceed 2.0 Wh.
- 1.5.11. Batteries or cells inside devices such as handheld radios, cameras, mobile telephones, or wristwatches that are carried by the driver or passengers are not considered to be part of the energy storage system if they are not electrically connected to the solar car, its instrumentation or control systems.
- 1.5.12. Capacitors are not considered to be part of the energy storage system if their total energy capacity is less than 10.0 Wh. Such capacitors must be automatically discharged to less than 60 V within five seconds of the solar car being placed in stage state (see Technical Regulations 1.29).
- 1.5.13. Energy storage packs must be mounted in the solar car so that they will be restrained in a 20 g acceleration in any direction.
- 1.5.14. The solar car must be designed so that any liquids or gases from a damaged energy storage pack cannot enter the occupant space.
- 1.5.15. Energy storage packs must be constructed so that each pack can be sealed using tamper-evident plastic seals, like 3 × 100 mm plastic cable ties. With seals fitted, it must not be possible to remove any cell from a pack without breaking the seal. Seals will be provided by and fitted by the event organiser at scrutineering.
- 1.5.16. Energy storage packs must have a means of being sealed so that no electrical connection can be made to the energy storage system. The seals will be tamper-evident plastic seals, like 3 × 100 mm plastic cable ties.

This regulation allows teams to have the energy storage system impounded inside the solar car. Examples of acceptable sealing mechanisms include:



- *Disconnecting each energy storage pack from the rest of the solar car and seeing a cover over the power connector on each pack*
- *Removing the energy storage packs from the solar car and sealing them in a box provided by the team*

1.5.17. Energy storage packs must be designed and constructed so that scrutineers can verify the cell models being used and the number of cells of each model.

1.5.18. Any external charging system that is used to recharge the energy storage system must meet the following requirements:

- The charger must be used with a residual current device
- The charger must be either permanently connected to the energy storage system, or connect to the energy storage system using an appropriate connector
- The output of the charger must be electrically isolated from any ac input
- Charging must stop automatically when the energy storage system is full or if a fault occurs

This regulation applies to all charging done in South Africa, including in the pits at Red Star Raceway.

1.5.19. TBC

1.6. Vehicle Identification

1.6.1. The solar car must have a unique identifier, which must be permanently attached to a substantial part of the solar car chassis or frame. The identifier must include a manufacturer code, the year of manufacture, and a serial number.

Teams may use a Vehicle Identification Number (VIN) or generate their own identifier, e.g., ABC-2022-01.

1.6.2. The solar car must have a space at least 220 mm wide and at least 110 mm high for mounting a rear vehicle registration plate. The registration plate must be mounted with the longest edge parallel to the road and parallel to the vehicle's axles, and with the letters upright. The registration plate must be within 50 mm of the rearmost part of the car. No part of the solar car may be in the region rearward of the registration plate in the range 15° up, 0° down, 45° left and 45° right from all parts of the registration plate.

1.7. Signage

1.7.1. Solar cars must incorporate event signage in unbroken rectangular spaces 200 mm high and 500 mm wide on both the left and the right sides of the solar car. Artwork will be available from the Sasol Solar Challenge website.

Stickers will be provided to teams requiring the signage only upon application and approval by the event organisers. Incorrect use of artwork will result in a sticker of the correct size and with the correct artwork being applied.



- 1.7.2. Teams must display their team number on the left and the right sides of the solar car, in digits that are more than 150 mm high and that are clearly visible against their background.
- 1.7.3. Event signage and team numbers must be completely visible from 3 m perpendicular to the side of the solar car and at a viewing height of 1.8 m above the ground.
- 1.7.4. Solar cars must have a front signage area on the solar car body, forward of the windscreen. The front signage area must contain:
- The name of the solar car, or the name of the team, or the number of the solar car, readable at 3 m perpendicular to the centre of the name
 - A 150 × 150 mm square event logo
- The entire front signage area must be visible in top view and in front elevation view and must not overlap with the solar collector. Artwork for the event logo will be available on the Sasol Solar Challenge website or a sticker for the event logo will be provided by the event organisers only upon request and approval.
- 1.7.5. The national flag of the country of entry must be displayed on the car, adjacent to the windscreen. The minimum size is 70 mm × 40 mm. The flag must not be broken.

1.8. Ballast

- 1.8.1. Each Challenger and Cruiser Class solar car occupant will be assigned ballast so that the combined mass of the occupant and their ballast is at least 80 kg.
- Adventure Class team occupants need not carry ballast and will not be weighed.*
- 1.8.2. Ballast must be supplied by the team and must be fashioned in such a manner to ensure the weight is tamper-proof and made from a durable material to eliminate the chances of breakage or damage.
- All ballast will be weighed during scrutineering to verify the weight. If a ballast weight discrepancy is found during scrutineering the event organisers will provide the team with supplementary ballast to make up the correct weight. Ballast may not consist of any functioning item of the solar car such as batteries etc. and must be non-functional.*
- 1.8.3. Teams must ensure each ballast weight is clearly indicated on the surface of the ballast. The weight indication must not wear down or disappear when being handled roughly.
- Each team must supply the appropriate amount of ballast for each individual solar car occupant, sharing of ballast between occupants is not permitted when occupants are driving in the solar car during competition hours.*
- 1.8.4. Challenger and Cruiser Class solar cars must have means of securing ballast within 300 mm of each occupant's hip point.
- 1.8.5. Supplementary ballast bags provided by the event organisers must be returned to the pack down area at the end of the event.



1.9. Tracker

- 1.9.1. The solar car must have provision to carry a self-contained tracker provided by the event organisers.

The tracker box will be 120 mm long, 120 mm wide and 70 mm high. The tracker will be self-powered. It will not require any electrical connection from the solar car. The mass of the tracker will not exceed 2 kg. It will emit radiofrequency energy with no more power than emitted by a mobile phone. The unit will be installed by the Crack technical specialist team during scrutineering.

- 1.9.2. When the tracker box is installed in the car, it must be possible to construct a right circular cone with its axis perpendicular to the top face of the box and an apex angle of 120° , and with the cone touching each edge of the top face of the box, so that no ray from the apex and within the cone passes through the ground or through any part of the car that is not radio transparent at frequencies between 300 and 3000 MHz. The tracker box may be tilted within the solar car.

Fibreglass and aramid composites, vinyl stickers, paint, clear acrylic, and clear polycarbonate are radio transparent if they do not include metal or carbon. Solar cells, carbon fibre composites and metal are not considered radio transparent.



- 1.9.3. The tracker unit must be returned to the event organisers at the end of the event.

1.10. Safety

- 1.10.1. Teams are responsible for the safety and roadworthiness of their solar cars. Compliance with the regulations and passing scrutineering does not mean that a solar car is safe, roadworthy, and fit for purpose.

- 1.10.2. Each team must engage a professionally qualified engineer to certify that the solar car is designed and constructed using sound engineering practice, meets the design parameters where stated, maintains stability while driving during testing, and is roadworthy and fit for being driven from Johannesburg to Cape Town on public roads. The certifying engineer must be qualified to certify vehicles for operation on public roads.

The Roadworthiness Certificate must be signed by a single certifying engineer. However, that engineer may engage other engineers to advise on aspects outside their expertise.

- 1.10.3. Any changes made after certification to items described in the roadworthiness certificate must be re-approved by the team's certifying engineer.



- 1.10.4. All parts of the solar car must be fixed so that they cannot detach while driving. Latched parts such as doors, canopies, and top shells must be secured with redundant or two-stage latches.

1.11. Occupant Cell

- 1.11.1. Solar car occupants must be enclosed in an occupant cell designed to protect them from injury.
- 1.11.2. Teams must provide documentation that specifies which parts of their solar car constitute the occupant cell.
- 1.11.3. When occupants are seated normally, with safety-belts and helmets on, no part of any occupant or their helmet may intersect with the convex hull of the occupant cell.
- 1.11.4. No point of any occupant's helmet may lie within 50 mm of the convex hull.

Imagine stretching a rubber skin around the occupant cell; no part of any occupant may touch the skin, and helmets must be more than 50 mm from the skin.

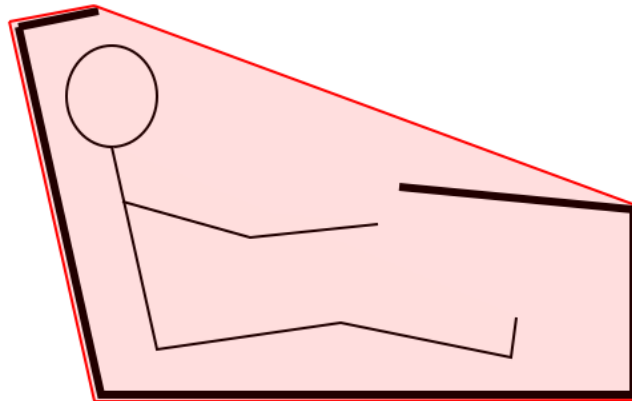

- 1.11.5. Each team must provide a description of how the occupant cell will protect the occupants from frontal impacts, side impacts and rollover impacts. This description must be endorsed by the team's certifying engineer. For teams wishing to do finite element analysis of the occupant cell, the minimum test loads are:

- Frontal impact: a 5 g load, opposing the direction of travel, applied to the front of the occupant cell in an area less than 250 mm high and less than 600 mm wide.
- Side impact: a 5 g load into the side of the occupant cell, applied adjacent to the driver's torso in an area less than 250 mm high and less than 600 mm wide.
- Top impact: a load with component 5 g down, 1.5 g sideways and 4 g backwards, applied at each possible area of contact between the occupant cell and the ground when the occupant cell is upside down; the contact area for each test load must have a diameter less than 150 mm.

Loads are based on the fully laden mass of the solar car. Teams must be able to show that the occupant cell structure will not fail with these test



loads, that any deformations will not impinge on the occupants, and that risk of impacts of the occupants with the interior of the car is minimised.

1.12. Seats

- 1.12.1. Cruiser Class solar cars must be designed to carry more than one occupant.
- 1.12.2. Each solar car occupant must have a seat that faces forwards. The driver's legs, viewed from above, must be within 10° of the forward direction.
- 1.12.3. Each seat must have a back and a head restraint that is behind the occupant's head. The distance from the hip point to the top of the head restraint must be at least 800 mm for front seats and at least 750 mm for rear seats (UNECE Regulations 17 and 25). The hip point may be approximated as shown in the diagram below.

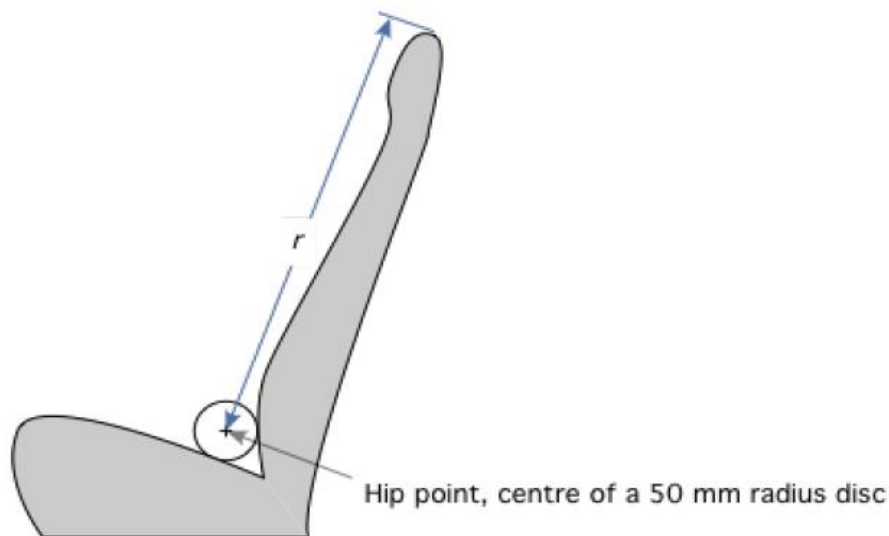

- 1.12.4. Each occupant's heels must be below their hip point.
- 1.12.5. No more than four solar car seats may be occupied while driving.

1.13. Occupant Space

- 1.13.1. Occupant space for each seat must comply with Act 93 of 1996: National Road Traffic Act, as shown in the following diagram. The 835 mm radius arm must be able to move 45° forwards, 25° backwards, and 7° on either side of vertical. The steering wheel, mirrors, seat backs, and head restraints may be inside the occupant space but must be designed to minimise the risk of injury in a crash. No other part of the solar car structure, including the windscreen, may be inside the occupant space.

This minimum occupant space requirement is based on a 50-percentile male and does not allow for a helmet. Taller team members may need more occupant space.

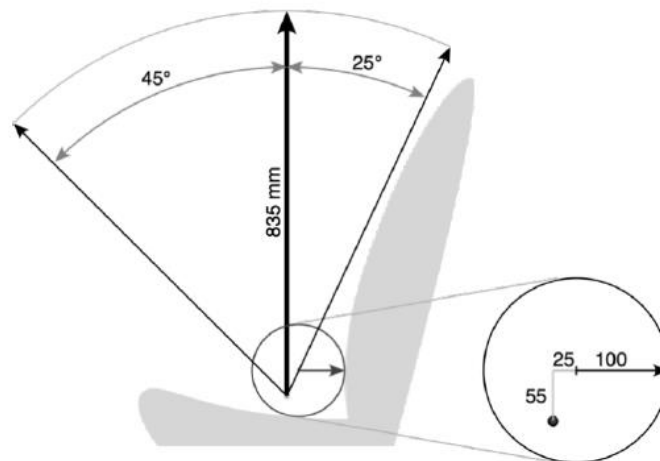

- 1.13.2. A Bridgestone World Solar Challenge manikin (“PVC Pat”) must fit into each seat. Dimensioned drawings of the manikin are available on the Sasol Solar Challenge website. The angle between the shoulder, hip and knees must be more than 90°.

1.14. Safety-belts

- 1.14.1. Safety-belts must be fitted for each seating position. Safety-belts must be compliant with at least one of the following standards: UNECE Regulation 16, US FMVSS 571.209, SFI 16.1, SFI 16.5, SFI 16.6, FIA 8853-2016, FIA 8854/98.

The occupant cell will provide the greatest protection when occupants are secured into the cell with four-point or five-point harnesses.

- 1.14.2. Safety-belts must be fitted and used according to the manufacturer’s instructions, or as approved by the team’s certifying engineer.
- 1.14.3. Safety-belt anchorages must meet the intent of UNECE Regulation 14. In particular:
- Upper anchorages for each seat must withstand a force of 13.5 kN applied to the upper safety-belt straps
 - Lower anchorages for each seat must withstand a force of 13.5 kN applied to the lower safety-belt straps
 - The location of anchor points must comply with the instructions of the safety-belt manufacturer, or with UNECE Regulation 14 Annex 3.
- 1.14.4. Compliance must be confirmed by the team’s certifying engineer.

1.15. Egress

- 1.15.1. Teams must demonstrate that all occupants can exit the solar car in less than 15 seconds, without assistance. Cruiser Class solar cars with more than four seats will be tested with four occupants.
- 1.15.2. Doors and canopies used for egress must be capable of being secured and released from inside the solar car and from outside the solar car.



- 1.15.3. Emergency openings, and the methods of opening, must be clearly indicated on the exterior of the solar car, and be visible to an emergency service first responder.
- 1.15.4. Occupants must be able to exit the solar car without assistance.
Teams may not use adhesive tape to secure exits.

1.16. Cooling and Hydration

- 1.16.1. Each solar car occupant must be provided with ventilation or cooling sufficient to ensure that they will not overheat. The team must describe the system, and have it approved by their certifying engineer.
- 1.16.2. Each solar car occupant must have space for at least two litres of drinking water (see Sporting Regulation 2.23.3).

1.17. Forward and Sideward Vision

- 1.17.1. Each driver, when seated in the normal driving position with safety-belt and helmet on, must be able to identify 75 mm high letters at every point of forward travel that is:
- 4m from the driver's eyes, and
 - between 0.4m below eye level and 0.7m above eye level, and
 - between 100° left and 100° right of the direction of travel

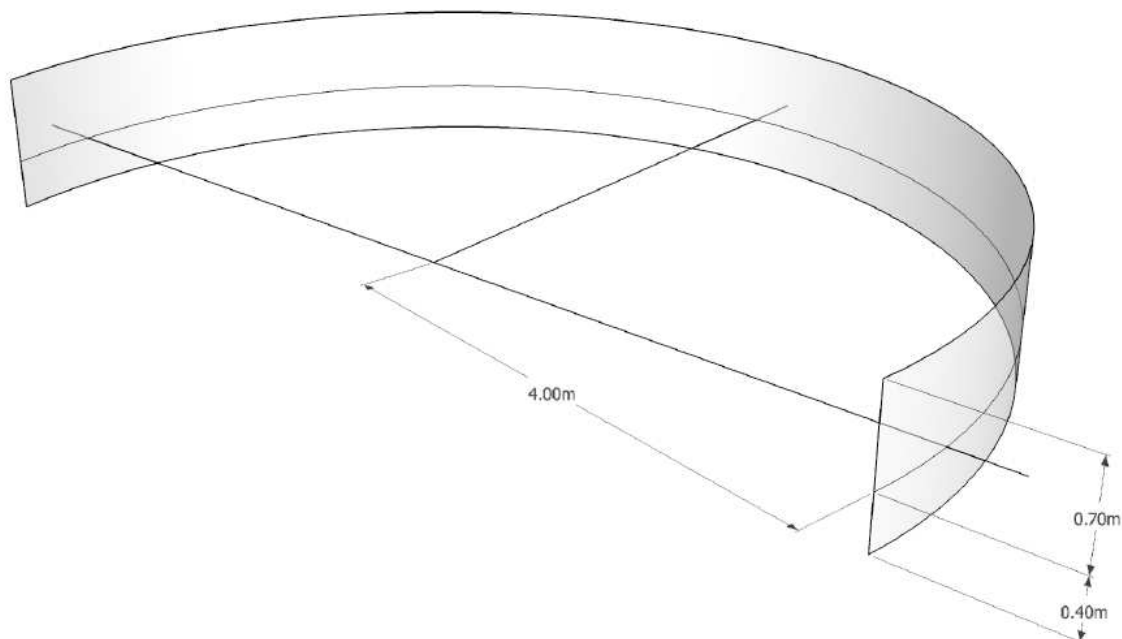

- 1.17.2. Forward and sideward vision must be achieved without the aid of mirrors, lenses, or electronic vision systems.
- 1.17.3. The windscreen that is used for forward and sideways vision must have an optical transmittance of more than 75%.
- 1.17.4. Traffic light colours must be discernible through the windscreen.



1.18. Rear Vision

- 1.18.1. The solar car must have rear vision systems that enable the driver, when seated in the normal driving position with the safety belt fastened, to see the ground in the shaded areas shown in the diagrams below (UNECE Regulation 46, Section 15).

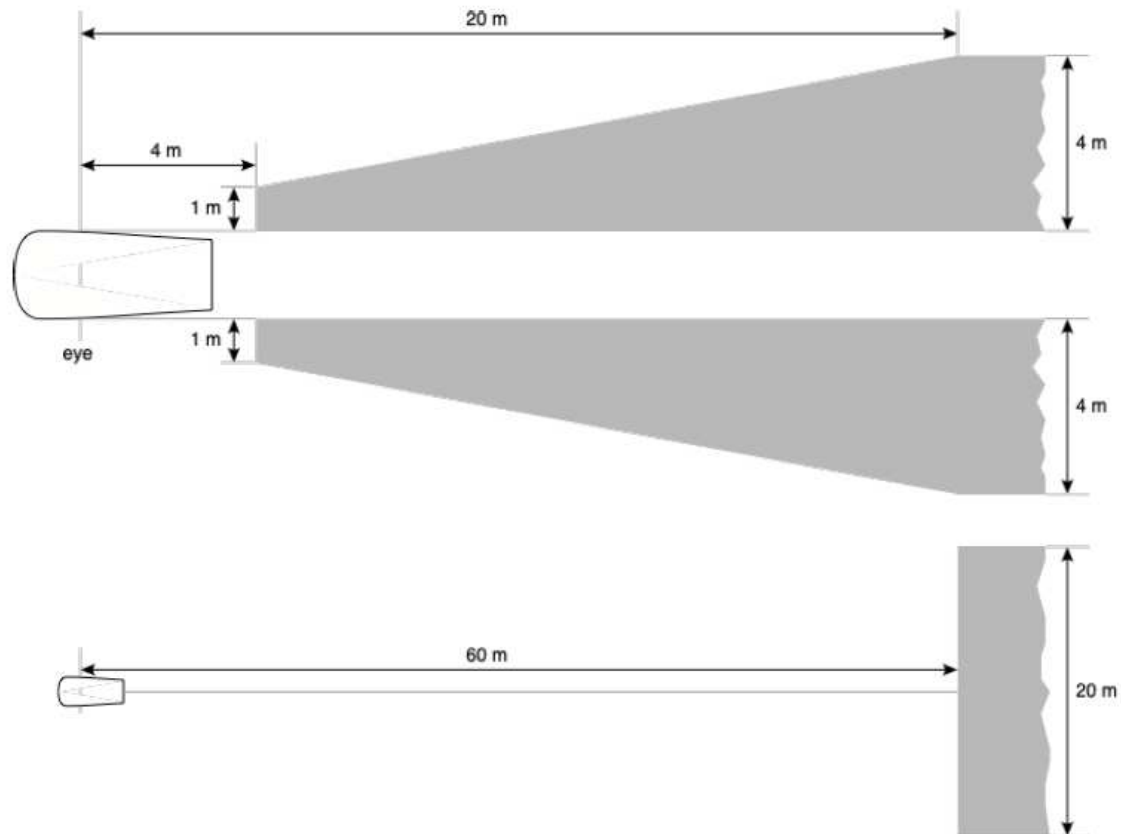

- 1.18.2. Rear vision systems may be electronic, mirrors, or both. Rear vision systems must operate whenever the solar car is in motion under its own power or about to be driven. Rear vision images must be oriented so that objects on the right of the solar car are on the right of the image.

1.19. Steering

- 1.19.1. Steering must be controlled by a steering wheel designed so that it cannot catch on any clothing while driving or when the driver exits the solar car.
- 1.19.2. Failure of any non-mechanical component of the steering system must not prevent effective steering of the solar car.
- 1.19.3. Steering shafts must be designed to reduce the risk of injury to the driver in a crash. A collapsible boss is an acceptable method to reduce steering wheel impacts.
- 1.19.4. Rear-wheel steering is not permitted. Specifically, no wheel that is rearward of the centre of mass of the solar car may be steered, either by a mechanism that the driver operates or via a servo motor. This does not



preclude suspension designs that are deliberately designed to have built-in bump steer or roll steer.

- 1.19.5. The solar car must be able to turn in each direction with a circle with a radius of 7.5 metres, measured to the extreme outer edge of the tyre track at ground level.

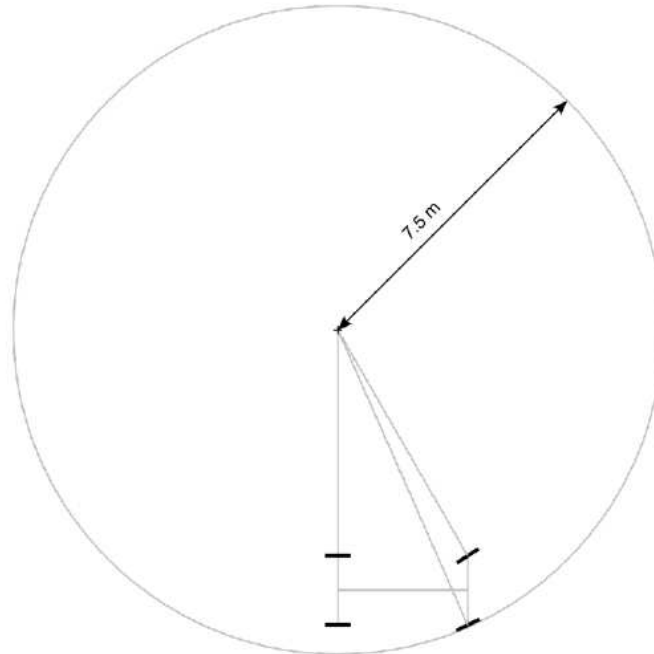

1.20. Stability

- 1.20.1. Solar cars must be able to negotiate a Figure-8 course in less than 9 seconds per side and less than 18 seconds overall.

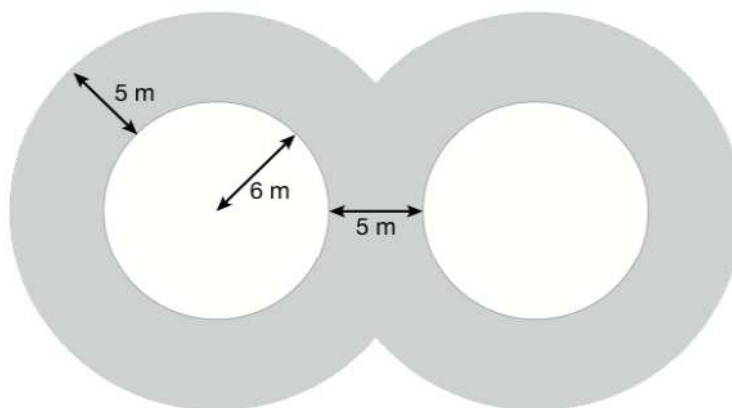

- 1.20.2. Solar cars must be able to negotiate a slalom course in less than 11.5 seconds.

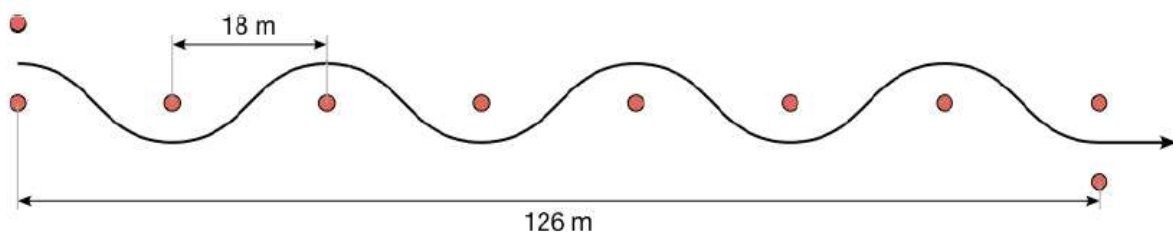



- 1.20.3. The solar car must be stable at all achievable speeds and in crosswinds likely to be encountered. Teams must provide analysis or test results that show that the car will be stable at high speeds and in crosswinds. This analysis must be approved by the team's certifying engineer.

In recent solar car events at least six cars left the road when hit by strong wind gusts. Wind gusts exceeding 100km/h is possible. Some of the factors affecting vehicle stability are presented in the informal discussion paper by Prof John Storey, "Stability Considerations", available on the Sasol Solar Challenge website.

1.21. Brakes

Braking requirements are based on UNECE Regulation 13-H.

- 1.21.1. The braking system must be approved by the team's certifying engineer.

- 1.21.2. The solar car must be equipped with independent service and secondary braking systems, so that if the service system fails the secondary system can still stop the solar car. The service and secondary braking systems must each apply mechanical braking effort to the road wheels.

Conventional cars have a brake pedal that operates two hydraulic master cylinders or one dual-chamber master cylinder. Each master cylinder operates callipers on a pair of wheels: either the front pair or the rear pair, or diagonal pairs. These arrangements meet the requirements for independent service and secondary braking systems – the service system is all four wheels, and the secondary system is one pair of wheels. For three-wheel cars with two wheels at the front, secondary braking should act on the two front wheels; for all wheel configurations, secondary braking must be adequate (Technical Regulation 1.21.9) and stable under braking (Technical Regulation 1.21.6).

- 1.21.3. Independent braking systems may share components deemed "not liable to failure" if they are amply dimensioned and readily accessible for maintenance. Components "not liable to failure" are:

- A brake pedal and its bearing
- Hydraulic cylinders and their pistons
- Hydraulic control valves
- Brake cylinders and their pistons
- Brake lever and cam assemblies

- 1.21.4. Hydraulic brake hoses and lines are regarded as liable to failure.

- 1.21.5. For Challenger and Cruiser Class vehicles, the service braking system must apply mechanical braking effort to all road wheels.

- 1.21.6. Braking must not cause the solar car to yaw. This requirement applies to both the service braking system and the secondary braking system.

- 1.21.7. For solar cars without anti-lock brakes, the front wheels must lock up before the rear wheels.

- 1.21.8. The service braking system must be able to stop the fully laden solar car within a distance

$$0.1 v + 0.0060 v^2$$



meters from any speed v , in km/h, that the solar car can achieve.

- 1.21.9. If the service braking system fails, the secondary braking system must be able to stop the fully laden solar car within a distance $0.1 v + 0.0158 v^2$

meters from any speed v , in km/h, that the solar car can achieve.

- 1.21.10. Solar cars must be equipped with a parking brake that can be operated by the driver from the normal driving position. The parking brake must hold the fully laden solar car on a 20% incline or decline.

1.22. Tyres

- 1.22.1. Tyres must be suitable for highway use and used in accordance with their manufacturer's recommendations always.

- 1.22.2. Solar cars must be fitted with tyres that are:

- Compliant with UNECE Regulations 30, UNECE Regulation 75 or US FMVSS 571.109, as indicated by an E or DOT approval marking on the tyre; or
- Otherwise approved by the event organisers

Experimental or prototype tyres must be approved by the South African road traffic authorities. The event organisers will administer this process, which requires the tyre manufacturer to submit a sample tyre and written technical specifications to the event organisers' office not later than 28 March 2022. A positive outcome to the approval process, which may take up to three months, is not guaranteed.

- 1.22.3. The speed rating of the tyres must be more than the maximum speed of the solar car. The load rating of each tyre must be more than the maximum static load imposed on it by the fully-laden solar car.

- 1.22.4. Tyres must be approved by the team's certifying engineer.

- 1.22.5. Tyres must be free of any apparent defect.

1.23. Driving and Reversing

- 1.23.1. The fully laden solar car must be able to start from rest on a 7% gradient.

- 1.23.2. The solar car must be able to be driven backwards under its own power with the driver seated in the normal position.

1.24. Lighting

- 1.24.1. Solar cars must be fitted with:

- Two rear stop lamps
- One central stop lamp
- Left and right front direction indicator lamps
- Left and right-side direction indicator lamps
- Left and right rear direction indicator lamps
- Two daytime running lamps



Headlamps and tail lamps are not required, though would increase the practicality score of Cruiser Class solar cars.

- 1.24.2. Stop lamps must emit red light. Direction indicator lamps must emit amber light. Daytime running lamps must emit white light.
- 1.24.3. Lamps must be compliant with UNECE Regulations 6, 7, and 87, or the SAE/DOT equivalents. Teams must demonstrate compliance by either:
- The presence of compliance markings on the lamps, or
 - Detailed documentation that demonstrates compliance with the photometric requirements of the UNECE or SAE/DOT regulations, confirmed by the team's certifying engineer.

Lamps approved for motorcycles may not meet these requirements.

- 1.24.4. Solar cars must have the correct type of lamp in each position. Lamps must be mounted with the correct orientation so that the photometric requirements of UNECE Regulations 6, 7, and 87, or the SAE/DOT equivalents, are met.

Lamp	UNECE Category	SAE/DOT Type
Front Indicators	1, 1a, 1b	I3, I4, I5
Rear Indicators	2a, 2b	I6
Side Indicators	5, 6	E2
Stop Lamps	S1, S2	S
Central Stop Lamp	S3	U3
Daytime Running Lamp	RL	Y2

Lamp position and visibility requirements are based on UNECE Regulation 48.

- 1.24.5. Rear stop lamps must be within 400 mm of the extreme outer edge of the solar car or each side, at least 600 mm apart (at least 400 mm apart if the solar car is less than 1300 mm wide), and at least 350 mm above the ground. The entire apparent surface must be visible 15° up, 5° down and 45° to the left and right.

The "apparent surface" of a lamp includes all parts of the lamp surface that emit light and are not obscured by other parts of the light-emitting surface.

- 1.24.6. A central stop lamp is required. Viewed from behind the solar car, the lateral position of the lamp must coincide with the visual centre of the solar car (see the examples in the following diagram). The lamp must be higher than a point 150 mm below the rear windscreen (if the solar car has a rear windscreen), and the bottom of the lamp must be higher than the top of the rear stop lamps. The entire apparent surface must be visible 10° up, 5° down and 10° to the left and right.

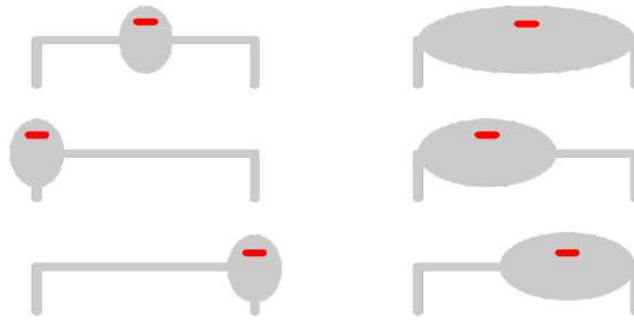

- 1.24.7. Front and rear direction indicator lamps must be within 400 mm of the extreme outer edge of the solar car on each side, at least 600 mm apart (at least 400 mm apart if the solar car is less than 1300 mm wide), and at least 350 mm above the ground.
- 1.24.8. Side indication indicator lamps must be less than 1800 mm behind the front most part of the solar car and within 400 mm of the extreme outer edge of the solar car on each side.
- 1.24.9. The entire apparent surface of direction indicator lamps must be visible 15° up and 5° down. Minimum horizontal visibility requirements (of the right direction indicator lamps) are shown in the following diagram.

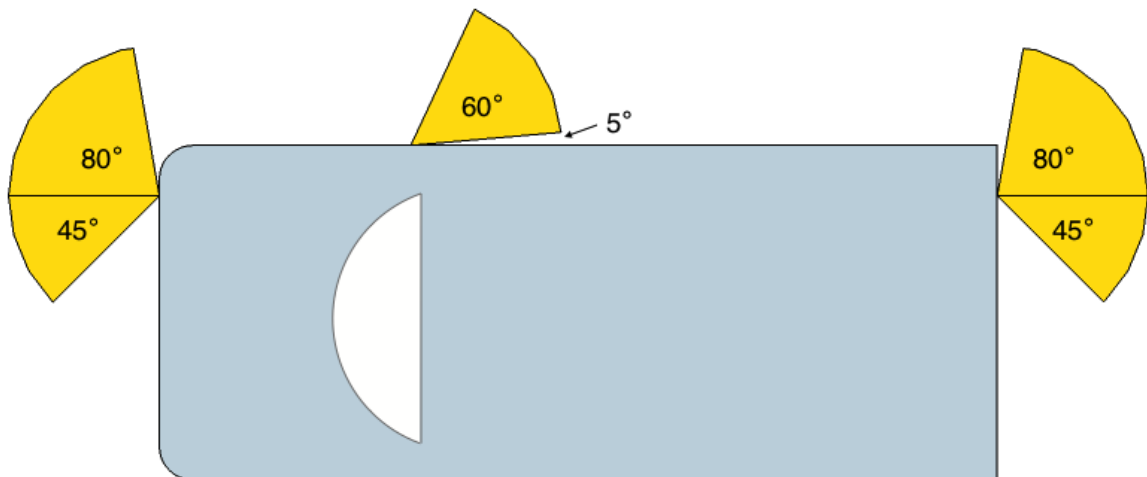

- 1.24.10. Direction indicators must flash at 90 ± 30 flashes per minute.
- 1.24.11. It must be possible to flash left and right direction indicator lamps simultaneously, as a hazard warning signal.
- 1.24.12. Daytime running lamps must be mounted at the front of the solar car, at least 600 mm apart (at least 400 mm apart if the solar car is less than 1300 mm wide), and at least 250 mm above the ground. The entire apparent surface must be visible 10° up, 5° down and 10° to the left and right. The entire apparent surface must be visible 10° up, 10° down and 20° outwards and 20° inwards.
- 1.24.13. Headlamps (if fitted) must be at the front of the solar car within 400 mm of the extreme outer edge of the solar car on each side, at least 600 mm apart (at least 400 mm apart if the solar car is less than 1300 mm wide), and at



least 500 mm above the ground. The entire apparent surface must be visible 15° upwards, 10° downwards, 45° outwards and 10° inwards.

1.24.14. The stop lamps must operate whenever driving is possible, and the brakes are applied.

1.24.15. The daytime running lamps must operate whenever driving is possible.

1.25. Audible Warning Device

1.25.1. An audible warning device complying with the intent of UNECE Regulation 18 must be fitted to the solar car.

1.25.2. Sound pressure level must be more than $L_A = 105$ dB measured 2 m from the horn.

The horn should be mounted so that solar car occupants are not subjected to excessive sound pressure levels.

1.25.3. The device must emit a continuous and uniform sound. The audible warning device must be capable of operating for 50,000 cycles of on for one second and off for four seconds.

1.26. Instrumentation

1.26.1. The following information must be provided to the driver always while driving.

- The speed of the solar car
- Whether the direction indicators are operating
- Whether the hazard lights are operating
- Energy storage system warnings
- Electronic rear vision images (if fitted)

1.26.2. This instrumentation must be powered from the energy storage system, and not from separate batteries.

1.27. Automatic Functions

1.27.1. Any cruise control function must automatically deactivate when the brake is operated, or the car is turned off.

Cruise control must not resume automatically following a brake operation.

1.27.2. Any automatic driving function must immediately deactivate on manual input or when the car is turned off.

Automatic driving must not resume automatically.

1.28. Electrical Safety

Electrical safety requirements are based on Section 5 of UNECE Regulation 100. The term "high voltage" means more than 60 V dc or more than 30 V rms ac.

1.28.1. Protection against direct contact with high-voltage parts, including conductors, must be achieved using double insulation, enclosures, or



barriers. It must not be possible to remove protection without the use of tools.

- 1.28.2. Protection against direct contact with high-voltage parts inside the driver, passenger and luggage compartments must be designed to exclude objects larger than 1 mm diameter (Ingress Protection rating IPXXD).
- 1.28.3. Protection against direct contact with high-voltage parts inside areas other than the driver, passenger, and luggage compartments must be designed to exclude fingers (Ingress Protection rating IPXXB).
- 1.28.4. Double insulation must meet the AS 3001/IEEE 100 definition: comprising both basic insulation and independent supplementary insulation that provides protection equivalent to that of the basic insulation. A single layer of reinforced insulation is also acceptable if it provides protection equivalent to double insulation.

Electrical tape and flimsy, easily displaced covers are unlikely to meet the requirements of supplementary insulation. The front surface of a photovoltaic cell is deemed to be double-insulated if properly encapsulated.

- 1.28.5. High-voltage energy storage packs must be marked with the high-voltage symbol shown in the following diagram.



- 1.28.6. The high-voltage symbol must also be visible on any enclosure or barrier that can be accessed without using tools if removing the enclosure or barrier exposes high-voltage parts.

Example: A motor controller contains high voltage parts, so their parts must be protected by an enclosure or barrier that requires tools to remove (Technical Regulation 1.28.1). If it is possible to access the motor controller enclosure without using tools (e.g., by opening the boot or tilting the solar collector) then the motor controller enclosure must have a high-voltage symbol on it.

- 1.28.7. The resistance between any exposed conductive part and each terminal of the energy storage system must exceed 100 V ohms, where V is the nominal voltage of the energy storage system.

This is equivalent to a maximum leakage current of 10 mA.

- 1.28.8. The resistance between any exposed conductive part and each terminal of every solar cell must exceed 100 V ohms, where V is the maximum circuit voltage of the solar collector.

- 1.28.9. A system must be implemented to monitor the isolation of the solar car's chassis and body as per Technical Regulations 1.28.7 and 1.28.8. This system may take the form of a permanently connected electronic device or a properly documented procedure of regular manual checks.

- 1.28.10. A fuse or circuit breaker, suitably rated to protect the wiring, must be mounted in or on each energy storage pack. Additionally, the dc interrupting current (i.e., dc breaking current) capacity of the device must



be able to interrupt the maximum possible short circuit current of the battery packs.

A typical solar car might use a 50 A fuse with a 15000 A dc interrupt rating. Fuses and circuit breakers intended for ac use might not meet this requirement. Teams must provide a manufacturer's datasheet clearly showing that the dc specifications of the device are adequate.

1.29. Electrical Safe State

- 1.29.1. The solar car must have a "safe state" which, in an emergency, minimises the risk of electrical fire and electrical shock to occupants, team members, emergency response personnel, and bystanders.

Safe state is for emergencies and for the complete shutdown of the car. In addition to safe state, a solar car may have a "standby" state that provides power to some subsystems outside of the energy storage packs.

- *A switch on the energy storage pack*
- *An air switch inside an energy storage pack, with an airline to a remote start button*
- *A fibre optic switch*

When in the safe state:

- Every conductor emerging from each energy storage pack must be galvanically isolated from every energy storage cell
- No voltage may be present across any pair of conductors emerging from energy storage packs or the solar collector
- No current may be present through any conductor loop that is external to the energy storage packs or the solar collector.

MOSFETS and other semiconductor devices are not considered to offer galvanic isolation.

- 1.29.2. Any conductor that is more than 200 mm from the nearest PV cell is outside of the solar collector.

- 1.29.3. All mechanisms for placing the solar car into safe state and maintaining safe state must be fail-safe; if an electrical activation mechanism fails, the solar car must automatically and immediately place itself into safe state and must remain in safe state indefinitely.

A simple design might use normally-open contactors in the energy storage packs, and have these contactors energised via a series loop of mechanical switches, all of which must be closed for normal solar car operation. If the loop breaks or any switch opens, the contactors will open, the power to the loop will be removed, and the vehicle will enter safe state.

Teams using other mechanisms, such as those incorporating solid-state switches (which can fail closed) or software (which can fail in many ways), must be able to demonstrate beyond a reasonable doubt that the probability of the mechanism failing to place the car into safe state is less than that of a system with normally-open contactors and normally-closed switches.



- 1.29.4. The driver must be able to place the solar car into safe state with a single simple action while seated in the normal driving position and without releasing the safety-belt. This activation device must be clearly labelled.
- 1.29.5. For emergency use, an activation device that operates with a single simple action immediately places the solar car into safe state must be provided on the exterior of the car. Multiple activations must not bring the car out of safe state. The activation device must be placed within a yellow disc with a diameter of 180 mm. also, in the yellow disk must be a blue equilateral triangle (minimum side length 150 mm) that contains a red flash, with the legend Emergency Electrical Isolation. In addition, there must be a clear instruction on how to operate the device (e.g., PULL or PRESS). The yellow isolation disc and the activation mechanism must be clearly visible to an emergency service first responder approaching the driver and must be within 100 mm of the base of the windscreen, adjacent to the driver egress opening, and not behind the driver.



Both activation mechanisms must be demonstrated at static scrutineering. The scrutineers may invite random members of the public to validate the ease of operation of the external emergency activation device.



Glossary

Battery	Electrochemical cells wired in series or parallel and housed in a single container
CB	Citizen's Band radio
Certifying Engineer	A professional engineer engaged by a team to report on compliance with regulations and roadworthiness requirements. The certifying engineer must be qualified to certify vehicles for operation on public roads.
Clerk of the Course	The person responsible for coordinating Dynamic scrutineering and the on-road segment of the event
DOT	Department of Transport
DST	South African Department of Science and Technology
Energy Storage Pack	A self-contained box containing components of the energy storage system, such as electrochemical cells and a battery management system
Entrant	The legal entity that completes the Participant Agreement and requests a place in the event for one or more teams. An entrant is typically a registered institution, organisation, or commercial entity.
Event Name	The official name of the event is the "Sasol Solar Challenge"
BWSC	Bridgestone World Solar Challenge
EVSE	Electric Vehicle Supply Equipment
FMVSS	United States Federal Motor Vehicle Safety Standards
High Voltage	More than 60 V dc or more than 30 V rms ac
FIA	Federation Internationale de'Automotive
ISF	International Solar Car Federation
Judge	A person invited to make subjective comment on Cruise Class attributes
Judge of Fact	A person recognised by the organiser as able to determine whether an event occurred (e.g., whether a team obstructed traffic)
Juror	A person appointed by the event to resolve disputes



Challenge Control Centre	The event organisers' operations centre
Participant	A person who has registered to participate in the event as a member of a team
PV	Photovoltaic
Regulations	2022 Sasol Solar Challenge Sporting Regulations, Technical Regulations and Team Manager's Guide
Road-ready	Ready to drive on public roads
Official Website	http://www.solarchallenge.org.za
Official Instagram	http://www.instagram.com/sasolarchallenge
Official Facebook	http://www.facebook.com/SASolarChallenge
Official Twitter	http://www.twitter.com/Solar_Challenge
Official Time	South African Standard Time GMT + 2
Scrutineering	The process of checking the solar car and other team vehicles for compliance with the regulations
Solar Collector	The solar car subsystem used to collect solar energy. It is typically an array of photovoltaic cells, with or without concentrators or reflectors, but other types of solar collectors are possible
Special Stage	Organisers implement special stages to the route to test participating teams' strategy skills and teamwork
Steward	An event official responsible for ensuring regulations are applied correctly and fairly
Team	A group of people registered by the entrant to participate in the event. An entrant may have more than one team participating in the event.
Team Manager	The person in charge of, and responsible for, the actions of a team
UHF	Ultra-High Frequency. Commonly refers to a South African two-way radio.
UNECE	United Nations Economic Commission for Europe, responsible for regulations for motor vehicles
VIN	Vehicle Identification Number